

ORIGINAL ARTICLE

## Housing-related control beliefs and independence in activities of daily living in very old age

FRANK OSWALD<sup>1</sup>, HANS-WERNER WAHL<sup>1</sup>, OLIVER SCHILLING<sup>1</sup> & SUSANNE IWARSSON<sup>2</sup>

<sup>1</sup>Department of Psychological Ageing Research, Institute of Psychology, University of Heidelberg, Germany, and <sup>2</sup>Department of Health Sciences, Lund University, Sweden

### Abstract

Control beliefs, i.e. a person's perceived control over his or her own behaviour, are important predictors of psychological functioning in old age. The aim of this study is to examine the mediating effect of housing-related control beliefs on the relationship between housing accessibility and independence in activities of daily living (ADL). Moreover, cross-national differences in five European countries were analysed, based on data from the ENABLE-AGE Project. Data were collected at home visits with 1918 very old people aged 75–89 years, living alone at home in Swedish, German, British, Hungarian, and Latvian urban areas. Assessments were based on standardized instruments with good psychometric properties. Correlations showed small to medium relationships between accessibility, housing-related control beliefs, and ADL independence. Further, multi-group structural equation modelling revealed that not only housing accessibility but housing-related control beliefs explain unique portions of variation in the independent performance of daily activities. In particular, participants with lower external control beliefs performed more independently in ADL. Though some differences among countries were observed, cross-national similarity in correlative patterns existed regarding control beliefs and independence in ADL. Introducing the concept of housing-related control beliefs into occupational therapy, comprehensively and cross-nationally, has the potential to increase our professional understanding of older people's housing situation.

**Key words:** Accessibility, ENABLE-AGE Project, home modification, housing

This research draws from links between psychological theories on perceived control (1–3) and theories on person–environment (P–E) fit processes in the domain of housing in later life (4–6). Psychological control theories support the argument that the extent to which individuals believe they can control their lives has advantages for all species capable of influencing their environment (7). There is substantial evidence supporting the notion that control beliefs are a major driving force in explaining the course and outcome of ageing (8–10). Among a broad range of predictors, so-called internal control beliefs (i.e. the belief that it is the “self” that is the major agent of outcomes) are of particular importance for independence in activities of daily living (ADL) in old age (11,12). In addition, external control beliefs (i.e. the belief that external forces are

causing outcomes) have revealed a negative relation with everyday activity (e.g. 13–15). Though internal and external control beliefs are partially related to each other in theory, such differentiated tendencies may be particularly pronounced in very old age.

Empirical literature refers to control beliefs in two different ways. Control beliefs can either be regarded as general attitudes, or in relation to specific domains of everyday life, such as health, cognitive functioning, or finances. Thus, control beliefs are labelled as “general” versus “domain-specific”. Although general control beliefs are good predictors of autonomy, they tend to be less useful for understanding what happens in particular domains of everyday life in detail (2). For example, age-related increases in internal control exist for the domains of work, finances, and control over marriage, whereas

decreases have been found for control over relationships with children, and control over one's sex life (16). One of the domains, becoming particularly important as people age, is the private home environment.

Findings from studies on everyday life in old age suggest a reduction in action range, especially in very old age (17). That is, older people spend more time at home than younger people do, particularly when they suffer from competence losses. According to data from the Berlin Aging Study, about 80% of older people's daily activities take place at home, particularly in very old age (18). Against this background, psychological control theory has recently been applied to the housing domain in later life (19–22). The construct of *housing-related control beliefs* serves to explain whether everyday activity is perceived as being contingent upon one's own behaviour related to housing arrangements (internal housing-related control) or whether housing is perceived as being contingent upon external influences (external housing-related control), i.e. luck, chance, fate, and powerful others.

From an environmental gerontology perspective, housing-related control beliefs explicitly address how ageing individuals interpret what Lawton coined environmental press or richness (23,24). Environmental press or richness is particularly important in very old age, as the majority of older people strive to preserve independence in their home environments (25,26), although functional limitations and accessibility problems increase with age. Particularly in very old age, the relationship between housing and daily independence is significant due to the increased vulnerability of older adults to environmental challenges (27,28).

Previous studies have focused on the impact of home hazards on negative health events, such as falls (28–30), while evidence on the relationship between P–E fit at home and independence in ADL is limited (22,28). Housing accessibility problems, i.e. discrepancies between functional limitations and environmental barriers, are a major indicator of P–E fit, or rather misfit (4–6). Going further, we argue that housing-related control is able to mediate possible links between housing accessibility and independence in ADL in very old age. An important implication for the occupational therapy (OT) profession arising from such links would be to consider housing-related control beliefs as a potentially critical variable supporting or hindering the outcome of home modification and housing consultation.

Still unmet in the empirical literature is the need to consider that housing is linked to the sociocultural background of a person (e.g. 31–33). Cultural differences in this regard are often addressed either

in terms of different migration patterns after retirement (e.g. 34), or as differences due to climate, religious background, and economics (e.g. 35,36). Given that cultural differentiation is important in order to understand the role of housing as people age, cross-national research on housing is needed to shed light on cross-country similarities and differences of relationships between housing accessibility, housing-related control, and ADL. An important implication for OT arising from such considerations is that cross-country similarity would support ongoing efforts for a more harmonized training of OTs across Europe, while differences would speak to the need for a continued consideration of country specifics in dealing with the dynamics between demographic ageing and barrier-free environments as a major target for OT interventions. Thus, we argue that housing-related control beliefs are critical for the understanding of the relation between housing accessibility and outcomes in terms of independence in ADL.

The aim of this study is to examine the mediating effect of domain-specific housing-related control beliefs on the relationship between housing accessibility and independence in ADL in very old age in five different European research sites, using the ENABLE-AGE Project (33,37) as the data source. Our hypothesis is that people who perceive their life at home as dependent upon their own responsibility (high internal control) and less upon luck, chance, fate, and powerful others (low external control), will be more independent in ADL, regardless of housing accessibility problems. Based on findings pointing to the crucial role of external control beliefs in later life, it is assumed that external control beliefs should reveal a stronger connection in the expected direction as compared with internal housing-related control beliefs. In addition, given the strong relation between housing and sociocultural background, we explore differences in these relationships in the five research sites involved.

## Material and methods

### Sample

This study is based on data collected for the first wave of the ENABLE-AGE Survey Study (33,37). The target sample in each country was approximately 2000 very old persons living in single-person households in geographically defined urban areas in Sweden, Germany, the United Kingdom (UK), Hungary, and Latvia. Very old individuals, particularly those living in single households, have been described as being particularly prone to “environmental press” (6), because of sensory, mobility, and

cognitive declines (38). In order to consider the different life expectancies in the countries involved, the samples in Sweden, Germany, and the UK consisted of persons aged 80–89 years, while in Latvia and Hungary the sample consisted of persons aged 75–84 years. In total, the ENABLE-AGE Survey Study sample included 1918 participants (78% women). As sociodemographic variables are concerned, differences in finances reflect lower income in the Eastern European compared with the Western European research sites, whereas differences in education were minor. As basic health-related indicators are concerned, participants were asked to give information on a disease list (44 items following the International Statistical Classification of Diseases and Related Health Problems, 10th revision, ICD-10), as well as on a list of 33 perceived symptoms (39). These basic health indicators varied among the national samples with slightly better health in the Western European compared with the Eastern European research sites. In all samples, the duration of living in the present dwelling was >21 years (for details see Table I).

Although the age range was limited to 10 years at each research site, housing accessibility problems and independence in ADL were significantly related to the age of participants (small to medium effect sizes). That is, the older the participants, the more accessibility problems were reported (Sweden:  $r = 0.33^{***}$ , Germany:  $r = 0.18^{**}$ , UK:  $r = 0.17^{**}$ , Hungary:  $r = 0.21^{***}$ , Latvia:  $r = 0.19^{**}$ ), and the older the participants, the less independent they

were in ADL (Sweden:  $r = -0.29^{***}$ , Germany:  $r = -0.16^{**}$ , UK:  $r = -0.14^{**}$ , Hungary:  $r = -0.14^{**}$ , Latvia:  $r = -0.30^{**}$ ). Given the role of calendar age in our study, further analyses will include age beside the core variables.

#### Instruments

**Housing accessibility.** Objective housing was operationalized as the number of environmental barriers in the home and the magnitude of housing accessibility problems, assessed by the Housing Enabler (40). For this study, a cross-national, reliable project-specific version was used (41). The instrument is administered in three steps, the first of which is the dichotomous assessment of the personal component of accessibility, measured through interview and observation and covering both functional limitations (13 items) and dependence on mobility devices (2 items). The second step is the assessment of the environmental component of accessibility, administered as an observation assessing the presence or absence of 188 environmental barriers in the home and the immediate outdoor environment. The third step is the computation of an accessibility score. Using a complex matrix including predefined severity ratings 1–4 (42), the individual profile of functional limitations/dependence on mobility devices is juxtaposed with the environmental barriers present in the home environment. The sum of all the predefined points is added to a score that indicates the magnitude of accessibility problems. In cases in

Table I. Sample description.

Variable	Sweden	Germany	UK	Hungary	Latvia
( $n = 1\ 918$ )	( $n = 397$ )	( $n = 450$ )	( $n = 376$ )	( $n = 392$ )	( $n = 303$ )
Year of birth	1912–22	1912–22	1912–22	1917–27	1917–27
Age range	80–89	80–89	80–89	75–84	75–84
Age: M (SD)	84.6 (3.1)	85.1 (3.2)	84.8 (2.7)	80.7 (2.9)	79.4 (2.6)
Gender (% women)	74.6%	78.4%	70.0%	80.6%	88.5%
Education (yrs of schooling): M (SD)	8.8 (2.2)	11.6 (2.6)	9.9 (1.9)	9.7 (3.0)	11.3 (3.4)
Income/month in €: M (SD) <sup>a</sup>	1015 (410)	1569 (799)	1044 (527)	216 (99)	100 (37)
Evaluation of financial resources: % (n) as					
Low	34.4 (130)	17.4 (76)	23.4 (86)	56.5 (218)	87.9 (262)
Average	54.5 (206)	73.3 (321)	65.5 (241)	39.9 (154)	12.1 (36)
High	11.1 (42)	9.4 (41)	11.1 (41)	3.6 (14)	0.0 (0)
General perceived health (1–5): M (SD) <sup>b</sup>	2.8 (1.1)	3.6 (0.8)	3.0 (1.0)	3.5 (1.0)	4.2 (0.7)
No. of diseases (0–44): M (SD) <sup>c</sup>	4.9 (2.9)	5.3 (3.0)	4.2 (2.7)	6.1 (3.9)	7.9 (3.4)
No. of symptoms (0–30): M (SD) <sup>c</sup>	7.3 (4.3)	8.0 (4.5)	8.1 (4.9)	10.7 (6.6)	13.8 (5.3)
Duration of living in same apartment / house (yrs): M (SD)	21.8 (17.4)	33.5 (19.4)	25.0 (18.3)	33.9 (19.2)	24.7 (16.6)

<sup>a</sup>In total 269 participants (14%) refused to give information on income per month.

<sup>b</sup>Subjective evaluation, single item, higher scores indicate lower subjective health (SF 36). <sup>c</sup>Higher scores indicate more reported diseases/symptoms.

which no functional limitations or dependence on mobility devices are present, the score is always zero; higher scores thus mean more accessibility problems.

*Housing-related control beliefs.* Housing-related control beliefs were assessed with the 24-item Housing-related Control Beliefs Questionnaire, based on the dimensions of "internal control" (8 items), "external control: powerful others" (8 items), and "external control: chance" (8 items) (scored 1–5) (20). The internal control subscale covers 8 items, such as "I have been able to set up my home in accordance with my own personal ideas", "Everything in my home will stay the way it is, no one is going to tell me what to do", or "I myself decide whose help to accept within or outside my home" (sumscore  $\alpha = 0.65$ ). In order to enhance reliability, the two external control sub-scales were combined, resulting in sufficient reliability for the 16 items, such as "Other people have told me how to arrange the furnishings in my home", "Whether or not I can stay in my home depends on luck and circumstance", or "Where and how I live has happened more by chance than anything else" (sumscore  $\alpha = 0.72$ ).

*Independence in ADL.* Independence in ADL was professionally assessed using the ADL Staircase (43), comprising five P-ADL items and four I-ADL items. This instrument is administered using a combination of interview and observation, and the target of assessment is dependence on assistance from another person when performing an activity. The assessment is recorded on a three-graded scale: independent, partly dependent, and dependent. Validity and reliability of the instrument have been widely demonstrated (27,43,44). We applied a rank-based data treatment approach, where the assignment of ranks is based on an item-wise comparison of response patterns in the sample (45,46). Moreover, *perceived* independence in ADL was self-rated on a single item (scored 0–10) from the Neuropsychological Aging Inventory (NAI) (47).

#### *Procedures and sample recruitment*

Instruments and questions were translated into the six languages involved (Swedish, German, English, Hungarian, Latvian, and Russian; not all observation items were translated into Russian), followed by iterative piloting in all countries. This was followed by three-day interviewer training courses focusing on reliable administration of all instruments (41). Thereafter, interviewers collected data at home visits. In Sweden, Germany, and Latvia the inter-

viewer teams consisted of OTs, while the UK and Hungarian teams were multidisciplinary (33,37). The initial sampling strategy was to draw participants at random from official national registers (e.g. address registers provided by national or local record holders) in all countries, but this was only possible in Sweden, Germany, and Hungary. In the UK and Latvia, official national registers are not made available for researchers in the way necessary for this project. Thus, in the UK, the sampling strategy relied on use of general practitioners' patient lists, while in Latvia participants were recruited at social day care centres and through older people's voluntary organizations. All participants were enrolled after informed consent, following the ethical guidelines and procedures for formal ethical consent of each country. All data were handled with strict anonymity. Since community-dwelling very old persons who live alone are considered to be very sensitive and vulnerable concerning extensive external contact with researchers, as expected the refusal rates were considerable (59% in Sweden, 67% in Germany, 39% in Hungary, 56% in Latvia; no information available in the UK due to ethical considerations). However, the most important reasons for refusal were comparable in all countries, such as "lack of interest or time", "poor health", "distrust/fear" and "interview too stressful".

#### *Data analysis and statistical methods*

Descriptive results were based on bivariate correlative findings, using the Spearman correlation coefficient for ordered categorical variables. Correlation coefficients are reported with  $p < 0.001$ ;  $p < 0.01$ ;  $p < 0.05$ . Regarding the effect sizes of correlation coefficients, data analyses follow Cohen's proposal (48), arguing that  $r$  from 0.1 to 0.3 is considered as a "small effect",  $r$  from 0.3 to 0.5 as "medium", and  $r \geq 0.5$  as "large" (note that these thresholds have been proposed with regard to Pearson correlations, and should be corrected if Spearman coefficients are used; however, these corrections result in only minor differences).

To test the hypothetically proposed relationships between domains, a structural equation model (SEM) approach was considered to be the optimal strategy. SEM offers several benefits, in particular in distinguishing the structural model, comprising relations between the theoretical constructs under study, from the measurement model, comprising the measurement of these constructs by observed indicators (for general overview on SEM, see (49)). In this study, the structural part of the model comprised the latent factors of external housing-related control beliefs (measured by 16 items, randomly

parcelled into four observed indicators), internal housing-related control beliefs (measured by 8 items, randomly parcelled into two observed indicators), and independence in activities of daily living (two observed indicators, i.e. the ADL-staircase rank and the single item rating of perceived independence).

SEM computations were conducted with the AMOS software (50), using the program's full information maximum likelihood estimator, which allows for inclusion of cases with missing values in some of the observed measures. Evaluation of model fit was based on the comparative fit index (CFI) and root mean squared error of approximation (RMSEA). We followed widely accepted "rules of thumb" for good model fit, i.e. CFI >0.90 and RMSEA <0.05. We also report the chi-squared test of overall model fit; however, this may not be used as indicator of model misfit, as it causes a well-known problem of over-rejection of true models due to large sample sizes. Thus, when other indices are consistently supporting a good fit, significance of the chi-squared test should not be seen as a sign of a badly fitting model (for discussion of SEM fit evaluation see (51,52)). It should also be noted that use of the above-mentioned maximum likelihood algorithm treats the data as interval scaled, which may be questioned for the measures included in our analysis. However, robustness of the SEM maximum likelihood estimation procedure against such violations of scale assumptions has been shown (53,54), such that the procedure can be recommended as long as the observed variables are not badly skewed (which was not the case for our data). According to conventional rules for graphical display of SEM, observed variables (i.e. measures contained in the database to be analysed) are represented by rectangles, whereas latent factors are shown as circles. Accessibility problems were included in the model by the Housing Enabler sumscore. Housing-related control beliefs and independence in ADL were computed as latent factors. Arrows symbolize path coefficients (i.e. regression coefficients in the SEM regression equations) and curved double-headed arrows symbolize covariance. Housing-related inter-

nal and external control beliefs were allowed to correlate, as implied in the theoretical considerations of this construct. Moreover, age was implemented into the models and allowed to correlate with housing accessibility problems due to the fact that participants from different sites were of different chronological age and that correlative findings showed a close link between accessibility problems and age. To reduce complexity, the reported SEM figure shows results (estimates of path coefficients and covariance) for the structural part of the model only, and leaves out results of the measurement part. The latter comprises equations for the observed indicators of the latent factors, which have been described earlier in the methods section and are symbolized in Figure 1 by the tiny unnamed rectangles. We also left out all variances that were estimated in this SEM computation.

To address differences between the different research sites in terms of structural relations, a multi-group analysis was conducted (multi-sample SEM). This particular modelling option allows for the simultaneous estimation of sub-sample specific model parameter values (e.g. regression coefficients, variances, covariance between model variables) if the total analysis sample consists of distinct sub-samples (49). In the present study, this method serves to compare between-country differences in the structural relations between the latent constructs as listed above.

## Results

### Descriptive findings

First, regarding correlations of subscales within each domain of interest, findings revealed that internal control and external control were only weakly linked ( $r = -0.17$ ), although the correlation is statistically significant (Table II). The correlation between the outcome variables (i.e. professionally assessed and perceived independence in ADL) revealed a moderate link ( $r = 0.49$ ), underpinning that both indicators can be considered as parts of the overarching domain of independence in ADL.

Table II. Correlations of p-e fit/accessibility problems, control beliefs, and independence in activities of daily living for all participants.

Spearman correlation coefficients	P-E fit	HCQ external	HCQ internal	ADL
P-e fit/accessibility problems (total score)	1.00			
Housing-related external control beliefs (HCQ <sup>a</sup> -E sumscore)	0.37***	1.00		
Housing-related internal control beliefs (HCQ-I sumscore)	-0.03	-0.17***	1.00	
Independence in activities of daily living (ADL sumscore)	-0.43***	-0.26***	0.06*	1.00
Perceived independence in activities of daily living (single score)	-0.43***	-0.36***	0.26***	0.49***

Spearman correlation,  $p < 0.001$ \*\*\*;  $p < 0.01$ \*\*;  $p < 0.05$ \*. <sup>a</sup>HCQ = "Housing-related Control Beliefs Questionnaire".

Second, the correlations between accessibility problems, housing-related control beliefs, and independence in ADL revealed statistically significant correlations, though with small to medium effect sizes. Thus, participants with more accessibility problems reported more external control beliefs, but not necessarily fewer internal control beliefs. Moreover, they were assessed as and perceived themselves as less independent in ADL. In particular, participants who reported low levels of external control and high levels of internal control in the domain of housing were more independent.

To reduce complexity, only a selection of bivariate correlations demonstrating relationships in the five different settings is displayed, i.e. between accessibility problems and housing-related control beliefs on the one hand and independence in ADL on the other. As can be seen in Table III, correlations between accessibility problems and perceived as well as professionally assessed independence in ADL are of medium to large effect sizes ( $r = -0.39$  to  $-0.52$ ), indicating that participants with accessibility problems were less independent in ADL in all sites. Concerning the relationships between external control beliefs and independence in ADL, consistently small to medium effect sizes ( $r = -0.25$  to  $-0.49$ ) indicate that participants with low levels of external control performed more independently in ADL in all sites. Correlations between internal control beliefs and both indicators of independence in ADL can be regarded as small effects ( $r < 0.29$ ), indicating that participants with more internal control beliefs were slightly more independent in ADL in all sites (except for Germany). In addition, links between housing-related external control beliefs and independence in ADL were closer compared with links between internal control and both outcomes in most sites, indicating that particularly housing-related external control beliefs might be important for independence in ADL. In contrast, however, Swedish participants had closer links between internal control and independence in ADL compared with external control.

In sum, descriptive findings already provided some support for our hypothesis on the bivariate level of analysis. That is, housing-related control beliefs played a substantial role in the relationships between housing accessibility problems and independence in ADL, with external control beliefs being more important than internal control (except for Sweden). As the comparability of relational patterns in all five research sites is concerned, the descriptive findings indicated a large degree of comparability with minor differences in Sweden.

Table III. Correlations of p-e fit/accessibility problems, control beliefs and independence in activities of daily living for research sites.

Spearman correlation	Independence in activities of daily living									
	ADL/IADL					Perceived independence				
	Sweden	Germany	UK	Hungary	Latvia	Sweden	Germany	UK	Hungary	Latvia
P-e fit/acc. problems	-0.41***	-0.39***	-0.52***	-0.49***	-0.50***	-0.48***	-0.41***	-0.44***	-0.51***	-0.51***
External control	-0.25***	-0.28***	-0.35***	-0.32***	-0.32***	-0.34***	-0.29***	-0.34***	-0.44***	-0.49***
Internal control	0.27***	0.03	0.14**	0.21***	0.20***	0.28***	0.18***	0.19***	0.24***	0.29***

Spearman correlation,  $p < 0.001$ \*\*\*;  $p < 0.01$ \*\*;  $p < 0.05$ \*

*Mediating effect of housing-related control beliefs on the relationship between housing accessibility and independence in ADL*

In order to address our research aims in detail and simultaneously for all five research sites, SEM computations were conducted to analyse complex relationships between the related domains. The findings are shown in Figure 1. Model fit parameters, RMSEA = 0.031 (90% confidence interval 0.028–0.035) and CFI = 0.929, indicate that the model fits our data well. Considerable amounts of explained variance were obtained for independence in everyday activities in Sweden (0.62), Germany (0.47), the UK (0.42), Hungary (0.51), and Latvia (0.64).

Figure 1 shows statistically significant direct negative paths between accessibility problems and independence in ADL in all sites, indicating that independence in ADL was directly related to low levels of housing accessibility problems. Moreover, there were substantial paths between accessibility problems, housing-related control beliefs, and independence in ADL, indicating that housing-related control beliefs mediated the impact of accessibility problems on independence in ADL. Further, the impact of age on independence in ADL was completely mediated through differences in accessibility problems and differences in housing-related control beliefs.

In a more detailed perspective, consistently high statistically significant positive paths between accessibility problems and external control beliefs as well as negative paths between external control and

independence in ADL indicate that the mediating effect of housing-related control beliefs between accessibility problems and independence in ADL was particularly evident for housing-related external control beliefs in Germany, the UK, Hungary, and Latvia. In these research sites, rather low path coefficients indicate that internal control beliefs did not mediate the relationship between accessibility problems and independence in ADL. That is, the greater the amount of accessibility problems that existed in the homes of German, British, Hungarian, and Latvian participants, the more they thought others, fate, chance, or luck were responsible for what happens at home and the less independent they were in ADL. The extent to which these participants believed that they had control over their homes was not important in this regard.

In contrast, for the Swedish sample the opposite relationship was observed. That is, a highly statistically significant negative path between accessibility problems and internal control beliefs as well as a positive path between internal control beliefs and independence in ADL indicated a mediating effect of housing-related internal control beliefs, whereas external control played a minor role. In other words, the lower the amount of accessibility problems that existed in the Swedish homes, the more the participants thought they were responsible for what happened at home and the more independent they were in their ADL. The extent to which these participants believed that others have control over their homes or that things at home happen due to luck or fate was not important in this regard.

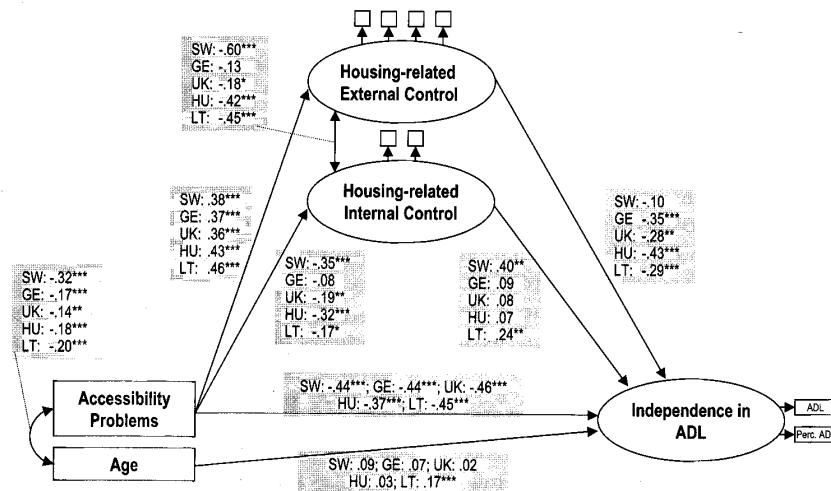

Figure 1. Multi-group SEM for P–E fit/accessibility problems, housing-related control beliefs and independence in daily activities. RMSEA = 0.031 (CI: 0.028–0.035); CFI = 0.929;  $\chi^2 = 433.0$  ( $p < 0.001$ ). Numbers attached to arrows indicate paths for Swedish, German, UK, Hungarian, Latvian sample with  $p < 0.001$ \*\*\*;  $p < 0.01$ \*\*;  $p < 0.05$ \*.

In terms of our hypothesis on the mediating effect of housing-related control beliefs, the data thus mostly confirmed that participants who had fewer accessibility problems perceived their life at home as less dependent upon luck, chance, fate, and powerful others (i.e. low external control beliefs) and were also more independent in ADL (with the exception of Sweden). However, the impact of housing-related external control beliefs was particularly prominent in this regard for participants in Germany, the UK, Hungary, and Latvia, whereas in Sweden independence in ADL was closely linked to high degrees of internal control beliefs, i.e. perceiving the home as dependent upon their own responsibility. Moreover, independence in ADL also directly depended to a large extent on low degrees of accessibility problems. In other words, housing accessibility remained important for explaining independence in ADL, while simultaneously considering housing-related control beliefs.

### Discussion

Addressing the construct of housing-related control in its relation with housing accessibility and independence in ADL is suggested in this research as a new approach to better understand person–environment dynamics as people age. As theoretically expected, the study provided the first empirical evidence for the mediating effects of domain-specific housing-related control beliefs on the relationship between housing accessibility and independence in ADL in very old age in five different European research sites.

Bivariate correlations showed, on the descriptive level, that independence in ADL was linked to low magnitudes of accessibility problems as well as to high internal and low external housing-related control beliefs. Next, again in accordance with our research hypothesis, data from multi-group SEM, simultaneously addressing links between different domains in all five research sites, revealed that housing-related control beliefs mediated the impact of accessibility problems on independence in ADL in very old age. That is, the more accessibility problems existed in the homes of our participants, the more they thought others, fate, chance, or luck were responsible for what happened at home (except for Sweden, where more accessibility problems were related to the perception that participants thought they were responsible for what happens at home) and the less independent they were in ADL. However, the impact of accessibility problems on independence in ADL was not fully mediated by housing-related control beliefs, supporting the view

that housing accessibility remained important for independence in ADL.

As far as our assumptions about the crucial role of external control beliefs in later life are concerned (e.g. 20), descriptive findings revealed closer links between independence in ADL and external compared with internal control. This indicates greater importance of external control beliefs compared with internal control beliefs in the domain of housing, at least at first glance. However, SEM data analyses revealed that external housing-related control beliefs served to mediate accessibility problems and independence in ADL in all sites, except for Sweden. Thus, our hypothesis is only partially supported by the data while the findings from Sweden lead directly to our exploratory research aim on differences between sites.

On the cross-country level of data analysis, the data revealed a high level of comparability among the five samples. However, concerning differences between research sites, we found that external control beliefs mediated the relationship between accessibility problems and independence in ADL in the German, British, Hungarian, and Latvian samples, whereas for Swedish participants internal control beliefs mediated the relationship between accessibility problems and independence in ADL. Thus, our findings indicate that the impact of control beliefs on independence in ADL is partially independent from the cultural background, although the impact of internal control beliefs on independence in ADL was particularly high in Sweden. In Sweden, compared with the other countries included in this study, housing adaptation services are more developed (55) and well known among older people and their significant others. All municipalities have OTs employed in their healthcare organizations, and the policy is to guarantee that older people can remain in their private homes as long as possible (see Iwarsson et al., this issue). As demonstrated by another study based on ENABLE-AGE Survey Study data (56), the same is true for provision of assistive devices. Thus, these types of findings can be interpreted in terms of a self-confident, proactive, and future-oriented handling of one's own life at home in very old age in Sweden. Presumably, the cross-country differences most of all reveal differences in social and healthcare policies across Europe.

Our findings extend existing evidence on the relationship between housing accessibility and outcomes such as independence in ADL (e.g. 6,27,28) with new data on the differentiated role of housing-related control beliefs among potentially vulnerable persons living alone in their private homes in very old age. By and large, a comprehensive understanding of housing and independence in ADL in later life

needs to cover the perceived agency-related challenges of housing, such as control beliefs. In light of our results, it seems that the relationship between housing and health outcomes in very old age is not only due to increased accessibility problems but also due to individual attitudes of the older person, such as the belief in whether he or she can control life at home and thus maintain everyday life (1,6,27). In addition, from a psychological control theory perspective, the data substantially contribute to the ongoing discussion of the impact of domain-specific control beliefs for major outcomes of ageing, i.e. behavioural independence in later life (e.g. 1,2,8). Thus, we want to further strengthen the need to address empirically the home environment as an important domain in later life, particularly in very old age (22,28). Further, one may also take such evidence as support for the view that stronger links between the psychology of ageing and OT research form a fruitful path of study in the future. From the vantage point of OT practice, our findings add to a deepened understanding of the ageing client being the target of home adaptation interventions. Knowledge of housing-related control beliefs may help support older people's personal preferences regarding their home environments.

Of course, our findings are subject to limitations. Three issues should be stressed in this regard: First, the generalization of the findings in terms of a common pattern of housing, control beliefs, and behavioural outcomes of ageing in terms of independence in ADL can be subject to discussion. It is necessary to consider that the participants from the different sites involved in the ENABLE-AGE Survey Study do not represent the full scope of cultural heterogeneity in their country. Thus, our cross-national sample was not representative of the countries included and was limited to urban settings and those living alone. Further analyses are needed to determine whether the findings remain stable against the background of national policies, norms, and housing programmes for older adults in different countries (33,37). Moreover, the impact of differences between the research sites on the findings, e.g. due to different languages, different compositions of interviewer teams, or different sampling strategies, cannot be excluded. However, these differences represent cultural diversity as also to be regarded as a natural source of variability of the ageing process in Europe. Second, it could be questioned whether we needed a multi-group SEM to address our hypothesis on the mediating effects of control beliefs. Although it would have been possible to address this assumption with other methods, comparative data in the multi-group SEM can be interpreted in terms of a validation of the findings in different sub-samples.

Moreover, the results from the multi-group analyses provided empirical support for the assumption of comparable patterns of housing, control beliefs, and behavioural outcomes in terms of independence in ADL in very old age, regardless of different objective, macro-level environmental circumstances. Finally, our sample consisted of very old persons living alone in their community dwellings. Thus, it should be kept in mind that the present study cannot reflect the full range of the ageing population, such as those who are "young-old", i.e. about 60–80 years of age, cohabiting older people, or older people living in institutional settings or sheltered housing.

Taken together, insights from our study support the assumption that the role of personal attitudes in the relationship of housing and outcomes of independence in ADL has been underestimated in earlier research. Measuring domain-specific housing-related control beliefs produces a promising and comprehensive extension of how the home is perceived by very old persons in relationship to age-related outcomes like everyday activities. The next steps of analyses need to extend the analyses of health-related outcomes in very old age by also addressing cognitive and emotional aspects of psychological well-being.

#### Acknowledgements

The project "Enabling Autonomy, Participation, and Well-Being in Old Age: The Home Environment as a Determinant for Healthy Ageing" (ENABLE-AGE) was funded by the European Commission (QLRT-2001-00334). The authors would like to thank all the consortium and national team members for their contribution. In particular, thanks are extended to Dr A. Sixsmith, Dept. of Primary Care, University of Liverpool, UK; Dr Z. Széman, Institute for Sociology, Hungarian Academy of Sciences, Hungary; Dr S. Tomsone; Riga Stradins University, Latvia. The Swedish ENABLE-AGE team is grateful for additional funding from the Swedish Research Council on Social Science and Working Life, the Swedish Research Council for Environment, Agricultural Sciences and Spatial Planning, and the Swedish Research Council. The authors thank all study participants, consortium and national team members, and sub-contractors for their contribution.

#### References

1. George LK. Perceived quality of life. In: Binstock RH, George LK, ed. *Handbook of aging and the social sciences*. 6th ed. San Diego: Academic Press, 2006:320–36.
2. Lachman ME. Locus of control in aging research: A case for multidimensional and domain-specific assessment. *J Psychol Aging*. 1986;1:38–40.

3. Lachman ME. Development in midlife. *Annu Rev Psychol.* 2004;55:305–31.
4. Carp FM, Carp A. A complementary/congruence model of well-being or mental health for the community elderly. In: Altman I, Lawton MP, Wohlwill JF, editors. *Human behavior and environment.* New York: Plenum Press; 1984. p. 279–336.
5. Kahana E. A congruence model of person–environment interaction. In: Lawton MP, Windley PG, Byerts TO, editors. *Aging and the environment: Theoretical approaches.* New York: Springer; 1982. p. 97–121.
6. Lawton MP. Environmental taxonomy: Generalizations from research with older adults. In: Friedman SL, Wachs TD, editors. *Measuring environment across the life span.* Washington, DC: American Psychological Association; 1999. p. 91–124.
7. Schulz R, Heckhausen J. Aging, culture and control: Setting a new research agenda. *J Gerontology: Psychol Sci.* 1999;54B: 139–45.
8. Baltes PB, Baltes MM, editors. *The psychology of control and aging.* Hillsdale, NJ: Erlbaum; 1986.
9. Lachman ME. Planning and control processes across the life span: An overview. *Int J Behav Development* 1993;16(Special issue).
10. Heckhausen J, Schulz R. A life-span theory of control. *Psychol Rev.* 1995;102:284–304.
11. Reich JW, Zautra AJ. Dispositional control beliefs and the consequences of a control-enhancing intervention. *J Gerontol: Psychol Sci.* 1990;45:46–51.
12. Baltes MM, Wahl H-W, Schmid-Furstoss U. The daily life of elderly Germans: Activity patterns, personal control, and functional health. *J Gerontol: Psychol Sci.* 1990;45:173–9.
13. Baltes MM, Freund AM, Horgas AL. Men and women in the Berlin Aging Study. In: Baltes PB, Mayer KU, editors. *The Berlin Aging Study.* Cambridge: Cambridge University Press; 1999. p. 259–81.
14. Clark-Plaskie M, Lachman ME. The sense of control in midlife. In: Willis SL, Reid JD, editors. *Life in the middle: Psychological and social development in middle age.* San Diego, CA: Academic Press; 1999. p. 181–208.
15. Lachman ME, Ziff M, Spiro A. Maintaining a sense of control in later life. In: Abeles RP, Gift HC, Ory MG, editors. *Aging and quality of life.* New York: Springer; 1994. p. 216–32.
16. Lachman ME, Weaver SL. Sociodemographic variations in the sense of control by domain: Findings from the MacArthur studies of midlife. *Psychol Aging.* 1998;13:553–62.
17. Moss MS, Lawton MP. Time budgets of older people: A window of four lifestyles. *J Gerontol.* 1982;37:115–23.
18. Baltes MM, Maas I, Wilms H-U, Borchelt MF, Little T. Everyday competence in old and very old age: Theoretical considerations and empirical findings. In: Baltes PB, Mayer KU, editors. *The Berlin Aging Study.* Cambridge, UK: Cambridge University Press; 1999. p. 384–402.
19. Nygren C, Oswald F, Iwarsson S, Fänge A, Sixsmith J, Schilling O, et al. Relationships between objective and perceived housing in very old age: Results from the ENABLE-AGE project. *Gerontologist*; in press.
20. Oswald F, Wahl H-W, Martin M, Mollenkopf H. Toward measuring proactivity in person–environment transactions in late adulthood: The Housing-related Control Beliefs Questionnaire. *J Housing for the Elderly.* 2003;17:135–52.
21. Oswald F, Schilling O, Wahl H-W, Fänge A, Sixsmith J, Iwarsson S. Homeward bound: Introducing a four domain model of perceived housing in very old age. *J Environmental Psychol*; in press.
22. Oswald F, Wahl H-W, Schilling O, Nygren C, Iwarsson S, Sixsmith A, et al. Relationships between housing and healthy aging in very old age. *Gerontologist*; in press.
23. Lawton MP. Environment and other determinants of well-being in older people. *Gerontologist.* 1983;23:349–57.
24. Lawton MP. Environmental proactivity and affect in older people. In: Spacapan S, Oskamp S, editors. *The social psychology of aging.* Newbury Park: Sage Publications; 1989. p. 155–64.
25. Kochera A, Straight A, Guterbock T. Beyond 50.05. A report to the nation on livable communities: Creating environments for successful aging. Research Report. Washington, DC: American Association of Retired Persons (AARP); 2005.
26. Diehl M, Willis S. Everyday competence and everyday problem solving in aging adults: The role of physical and social context. In: Wahl H-W, Scheidt RJ, Windley PG, editors. *Aging in context: Socio-physical environments (Annu Rev Gerontol Geriatr 2003).* New York: Springer; 2004. p. 130–66.
27. Iwarsson S. A long-term perspective on person–environment fit and ADL dependence among older Swedish adults. *Gerontologist.* 2005;45:327–36.
28. Oswald F, Wahl H-W. Housing and health in later life. *Rev Environmental Health.* 2004;19:223–52.
29. Gitlin LN. Conducting research on home environments: Lessons learned and new directions. *Gerontologist.* 2003; 43:628–37.
30. Stark S. Removing environmental barriers in the homes of older adults with disabilities improves occupational performance. *Occup Ther J Research: Occupation, Participation and Health.* 2004;24:32–9.
31. Fry CL. Kinship and supportive environments of aging. In: Wahl H-W, Scheidt RJ, Windley PG, editors. *Aging in context: Socio-physical environments (Annu Rev Gerontol Geriatr 2004).* New York: Springer; 2003. p. 313–33.
32. Iwarsson S, Wahl H-W, Nygren C. Challenges of cross-national housing research with older people: Lessons from the ENABLE-AGE project. *Eur J Ageing.* 2004;1:79–88.
33. Iwarsson S, Wahl H-W, Nygren C, Oswald F, Sixsmith A, Sixsmith J, et al. Importance of the home environment for healthy aging: Conceptual and methodological background of the European ENABLE-AGE project. *Gerontologist*; in press.
34. Serow WJ, Friedrich F, Haas WH. Residential relocation and regional redistribution of the elderly in the USA and Germany. *J Cross-Cultural Gerontol.* 1996;11:293–306.
35. Hay R. Sense of place in developmental context. *J Environmental Psychol.* 1998;18:5–29.
36. Miller D, editors. *Home possessions: Material culture behind closed doors.* Oxford: Berg; 2001.
37. Iwarsson S, Sixsmith J, Oswald F, Wahl H-W, Nygren C, Sixsmith AJ, et al. The ENABLE-Project: Multi-dimensional methodology for European housing research. In: Vestbro DU, Hürol Y, Wilkinson. N, editors. *Housing research methodologies.* Gateshead, UK: Urban International Press; 2005. p. 70–90.
38. Baltes PB, Smith J. Multilevel and systemic analyses of old age. Theoretical and empirical evidence for a fourth age. In: Bengtson VL, Schaie KW, editors. *Handbook of theories of aging.* New York: Springer; 1999. p. 153–73.
39. Tibblin G, Bengtsson C, Furunes B, Lapidus L. Symptoms by age and sex. *Scand J Prim Health Care.* 1990;8:9–17.
40. Iwarsson S, Slaug B. *Housing Enabler. An instrument for assessing and analyzing accessibility problems in housing.* Lund, Sweden: Studentlitteratur; 2001.

41. Iwarsson S, Nygren C, Slaug B. Cross-national and multi-professional inter-rater reliability of the Housing Enabler. *Scand J Occup Ther*. 2005;12:29–39.
42. Steinfeld E, Schroeder SD, J, Faste R, Chollet D, Bishop M, Wirth P, et al. Access to the built environment: A review of the literature. Washington, DC: Government Printing Office; 1979.
43. Sonn U, Hulter-Åsberg K. Assessment of activities of daily living in the elderly. A study of a population of 76-year-olds in Gothenburg, Sweden. *Scandinavian Journal of Rehabilitation Medicine*. 1991;23:193–202.
44. Iwarsson S, Isacson A. Quality of life in the elderly population: An example exploring interrelationships among subjective well-being, ADL dependence, and housing accessibility. *Archives of Gerontology and Geriatrics*. 1997;26(4): 71–83.
45. Iwarsson S, Isacson A, Lanke J. ADL dependence in the elderly population living in the community: The influence of functional limitations and physical environmental demand. *Occup Ther Int*. 1998;5:173–93.
46. Iwarsson S, Lanke J. Alternative data treatment principles for categorical ADL data. *Int J Rehabil Res*. 2004;27:195–201.
47. Oswald WD. *Neuropsychological Aging Inventory (NAI)*. Göttingen: Hogrefe; 2005.
48. Cohen J. *Statistical power analysis for the behavioral sciences*. Hillsdale, NJ: Erlbaum; 1988.
49. Bollen KA. *Structural equations with latent variables*. New York: Wiley; 1989.
50. Arbuckle JL, Wothke W. *Amos 4.0 User's Guide*. Chicago: SmallWaters; 1999.
51. Marsh HW, Balla JR, Hau K-T. An evaluation of incremental fit indices: A clarification of mathematical and empirical properties. In: Marcoulides GA, Schumacker RE, editors. *Advanced statistical modeling*. Mahwah, NJ: Erlbaum; 1996. p. 315–53.
52. Hu L, Bentler PM. Cutoff criteria for fit indexes in covariance structure analysis: Conventional criteria versus new alternatives. *Structural Equation Modeling*. 1999;6:1–55.
53. West SG, Finch JF, Curran PJ. Structural equation models with nonnormal variables. In: Hoyle RH, editor. *Structural equation modeling*. Thousand Oaks, CA: Sage Publications; 1995. p. 56–75.
54. Enders CK. The impact of nonnormality on full information maximum likelihood estimation for structural equation models with missing data. *Psychological Methods*. 2001;6:352–70.
55. Fänge A, Iwarsson S. Challenges in the development of strategies for housing adaptation evaluations. *Scand J Occup Ther*; in press.
56. Löfqvist C, Nygren C, Széman Z, Iwarsson S. Assistive devices among very old people in five European countries. *Scand J Occup Ther*. 2005;12:181–92.